



SCALE **AD**

# Town hall

February 2021



# Agenda

---

- Tilbakeblikk på 2020
- ScaleAQ bygger for fremtiden
- Et skifte i landbasert satsing
- Finansiell status
- ScaleUp 250
- Sjøbasert blir ett selskap
- En spydspiss mot laksenæringen
- Bærekraft
- Innovasjon



# Tilbakeblikk på 2020

---

2020 ble et heftig år, en skikkelig krevende berg- og dalbane!



# Tilbakeblikk på 2020

---

- Pandemi

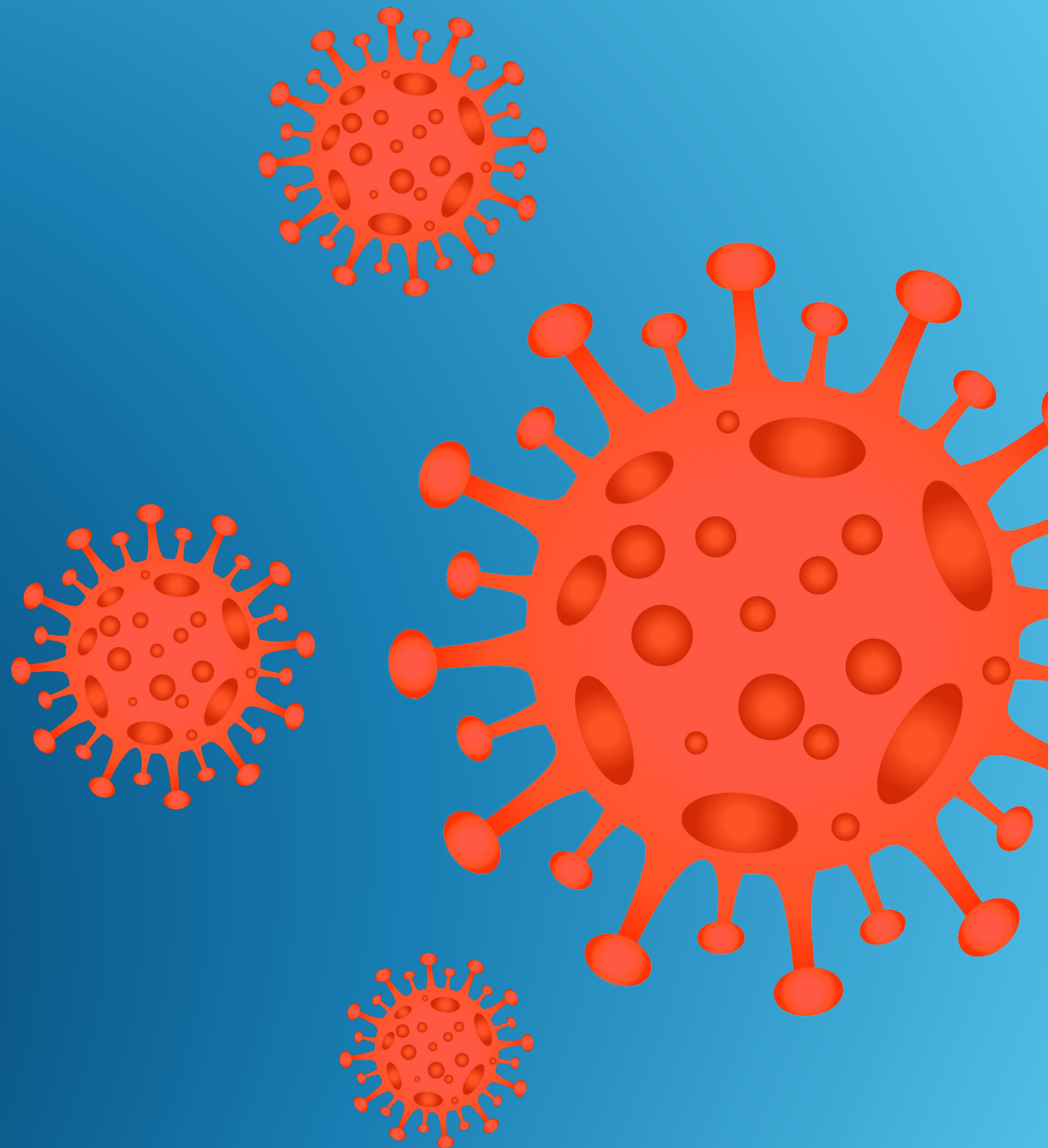



# Tilbakeblikk på 2020

---

- Hjemmekontor
- Smittevernregler





HACKED

# Tilbakeblikk på 2020

- Hacking





# Tilbakeblikk på 2020

---

- To selskap på vei til å bli ett
- Omstrukturering
- All time high ordrebok
  
- Og en fantastisk laginnsats!





# ScaleAQ bygger for fremtiden



## ScaleUP 250 – organizational actions

- **3 focused business areas** Sea-based / Land-based / Boat - with dedicated management teams
- Acquisitions of new companies **on-hold** until further notice to ensure focus on integration and improvement measures
- Optimize **Canada, UK and Oceania** from stand-alone companies to a pure role as KAM and service function
- Changes in the **Mediterranean** set-up - sales in these markets will be handled directly from Norway – strong local partnership on service and installation to be established where required
- Initiation of sales process for department **Sykkylven**
  
- A **clear prioritization of development work** for the next 6 - 12 months
- Closing of Project **OKDA**
- Mechatronics is moved to Innovation & Development, **closer collaboration across product groups**
  
- The department in Haugesund takes increased responsibility for stronger control of **global project management**
- Integrated **Supply Chain** (South / Central / North), Bømlo is being built as a base in the south
- Relocation from Frakkagjerd, to more suitable premises in **Haugesund**





# Skifte i landbasert satsing – fra turn-key til CAS

- ScaleAQ legger videre satsing på landbaserte turn key-prosjekter på hylla
- Alle pågående prosjekter vil ferdigstilles som planlagt
- ScaleAQ spisser satsingen på **CAS (Closed Aquaculture Systems)**
- Vi skal bygge på synergier mot det vi er gode på i ScaleAQ
  - Sjøanlegg
  - Foring, overvåkning og sensorikk
  - Rådgivning
- Selskapet reorganiseres nå for dette skiftet
  - Nedbemanning på ca. 6-8 personer
  - Et mindre kjerneteam beholdes



# Finansiell status

---



# NØKKELTALL FINANS (MNOK)

## Omsetning \*)

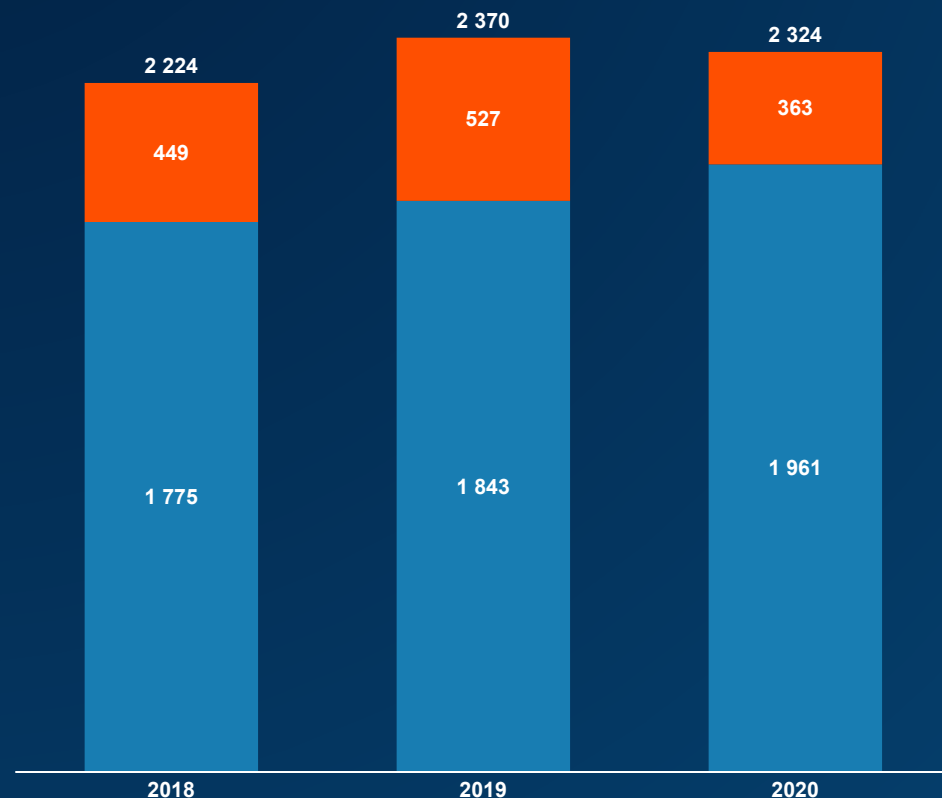

**Moen Marin**  
**Seabased**

## Driftsresultat uten avskrivninger (EBITDA) \*)

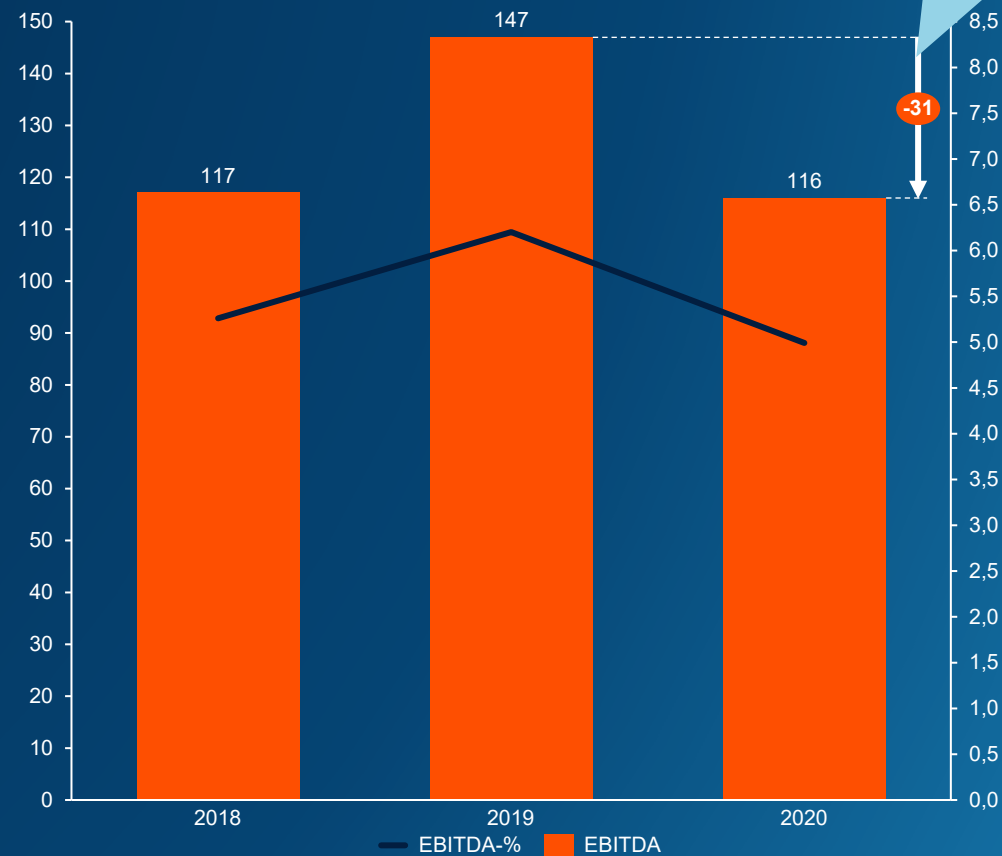

\*)Scale Aquaculture Group ex AquaOptima – discontinued business



# SOLID POSISJON I DET GLOBALE LAKSEMARKEDET

## Omsetning fordelt på regioner

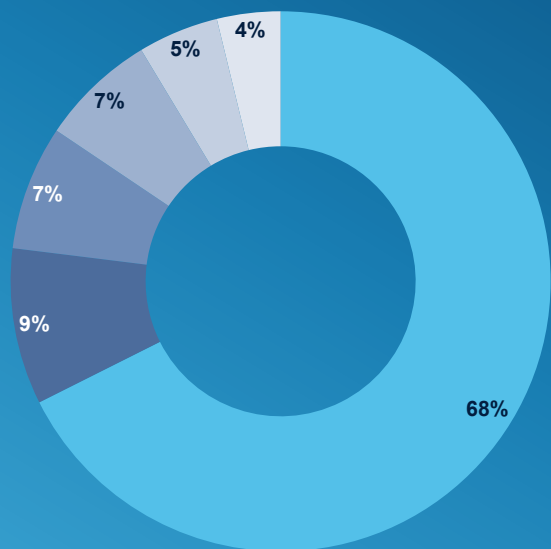

Norway Iceland UK  
Chile Canada Other

2.32 mrd NOK

## Omsetning fordelt på produkttype

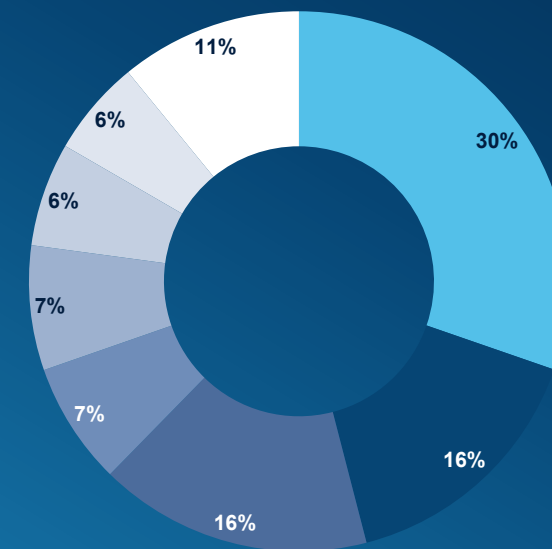

Cages Feeding Nets Camera  
Boats Mooring Service Other



# «ALL TIME HIGH» ORDREINNGANG

Utvikling ordreserve jan 2019 – des 2020

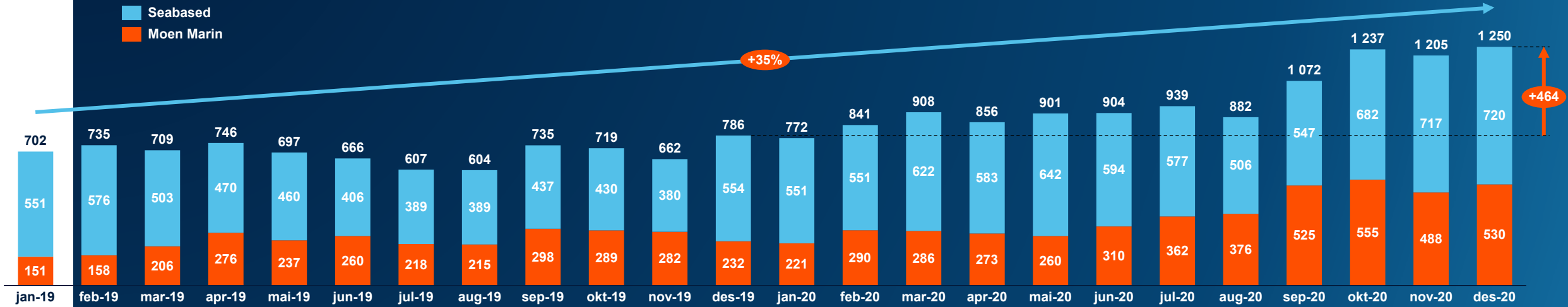



# ScaleUp 250

## Omsetning

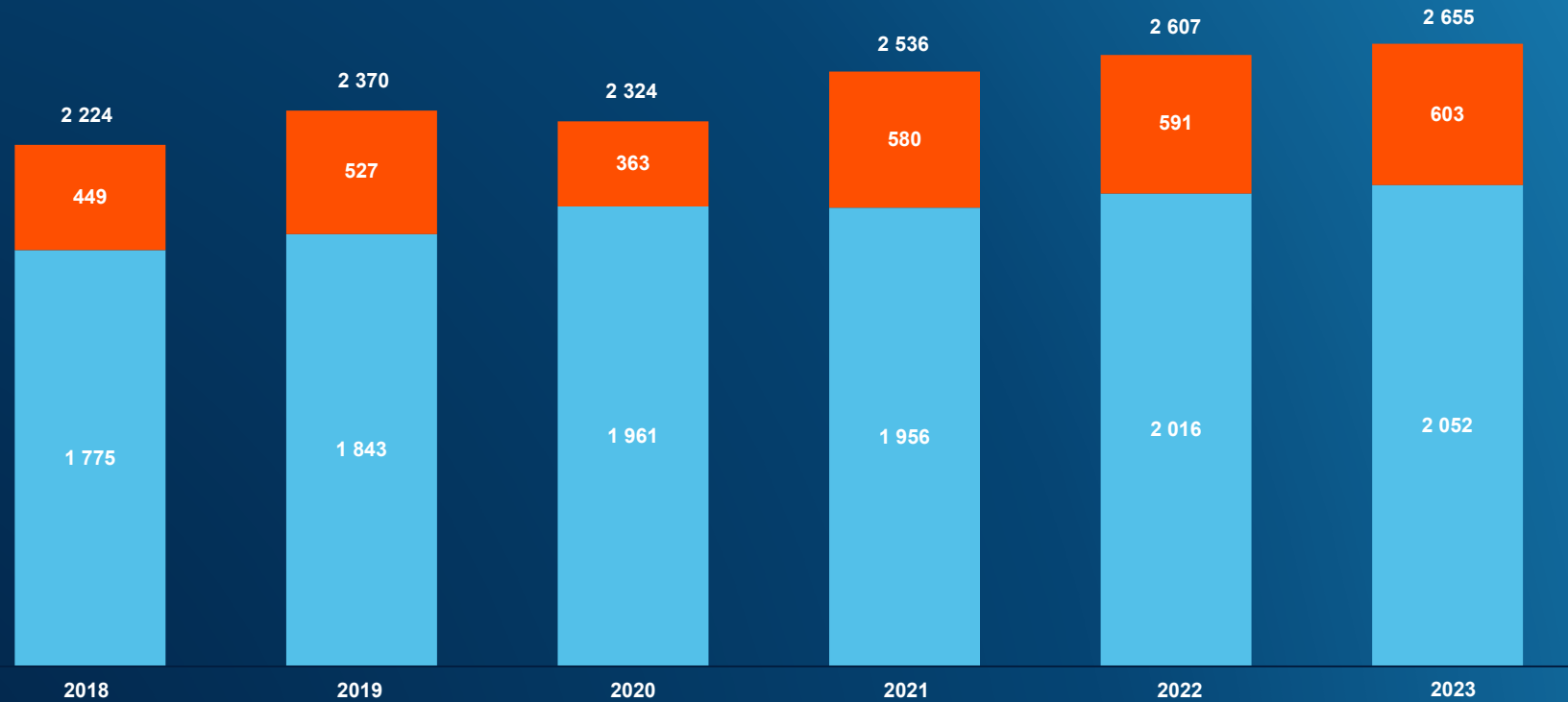

- Moen Marin
- Seabased



## Vi har et solid utgangspunkt: Sammen skal vi bli enda bedre

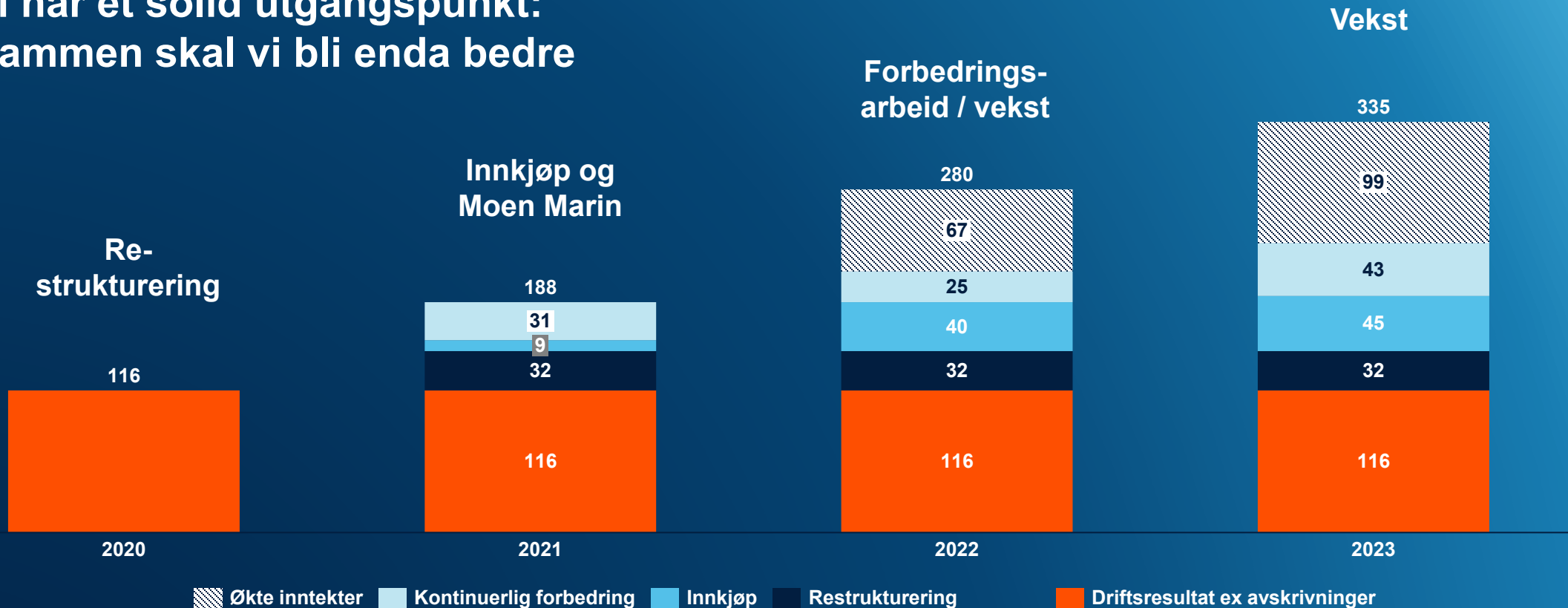

- Fokus på laks
- Restrukturering
- Samkjøring organisasjon

- Samkjøring organisasjon
- Innkjøp
- Forbedring i måten vi arbeider på / lavere kostnader frakt mv
- Moen Marin tilbake til gamle høyder

- Innkjøp
- Forbedring i måten vi arbeider på / lavere kostnader frakt mv
- Ta markedsandeler
- Satse på utleie

- Innkjøp
- Forbedring i måten vi arbeider på
- Ta markedsandeler
- Satse på utleie



# Sjøbasert blir ett selskap

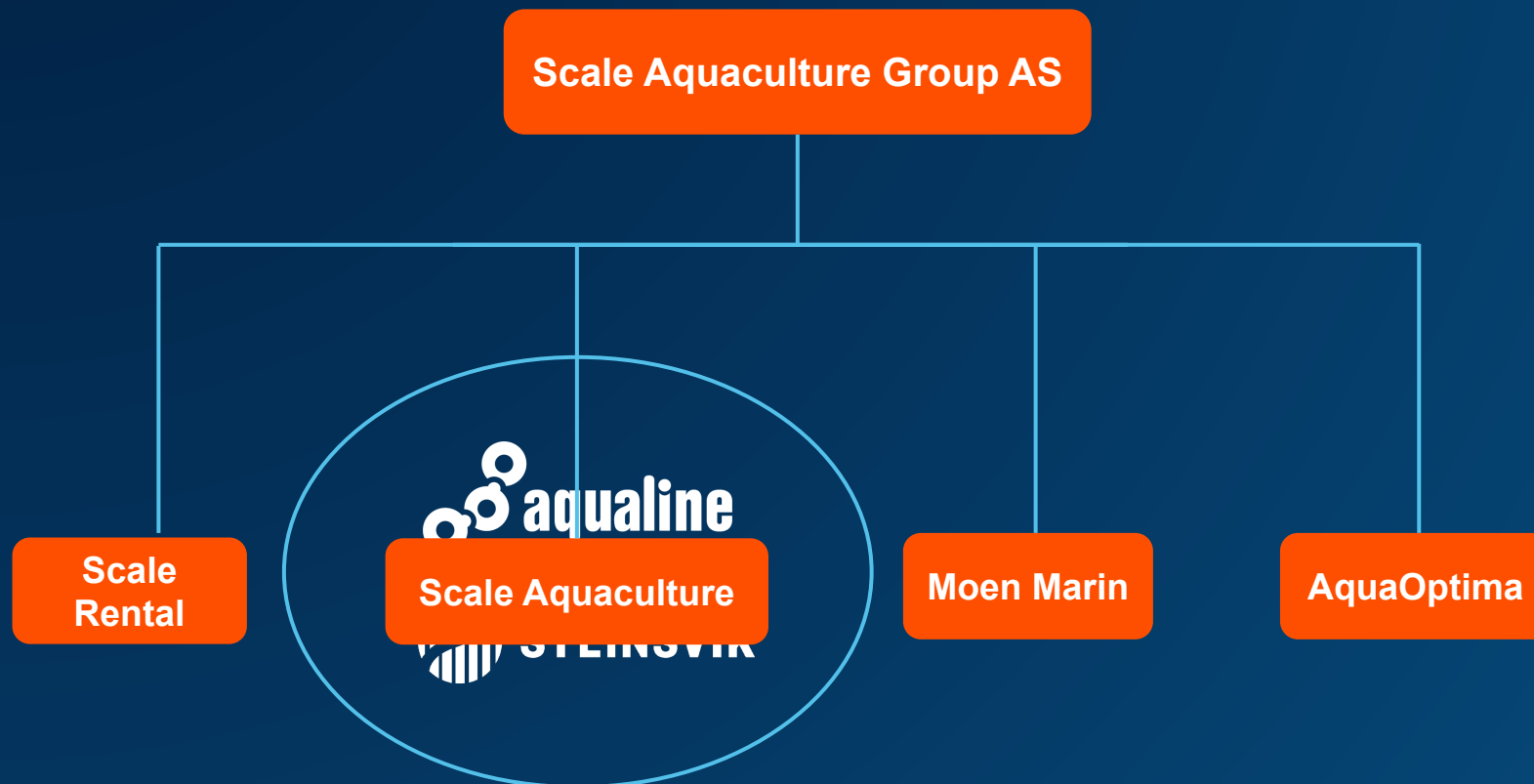

- Business as usual
- Legal struktur = operasjonell struktur
- Scale Rental – eget selskap for til bruk for hele konsernet
- Ingen konsekvens for de ansatte bortsett fra navneskiftet
- Forsterke merkevarebygging – unngå forvirring i markedskommunikasjon – Scale vs Steinsvik og Aqualine
- Bidra til å bygge et Scale – etablering av verdibasert kultur på tvers av Scale – bygge ned selskapstekningen



# SCALEAQ – EN SPYDSPISS I LAKSENÆRINGEN

# SCALE AQ



Finans

Salg og  
marked

Innovasjon  
og utvikling

Service

Prosjekt

Operations

HR

BÆREKRAFT – INNOVASJON – DIGITALISERING

Digital

IT

Supply  
Chain

En **partner** for  
oppdrettsnæringen

*Fra skreddersydde  
løsninger til komplette  
nøkkelferdige prosjekter*

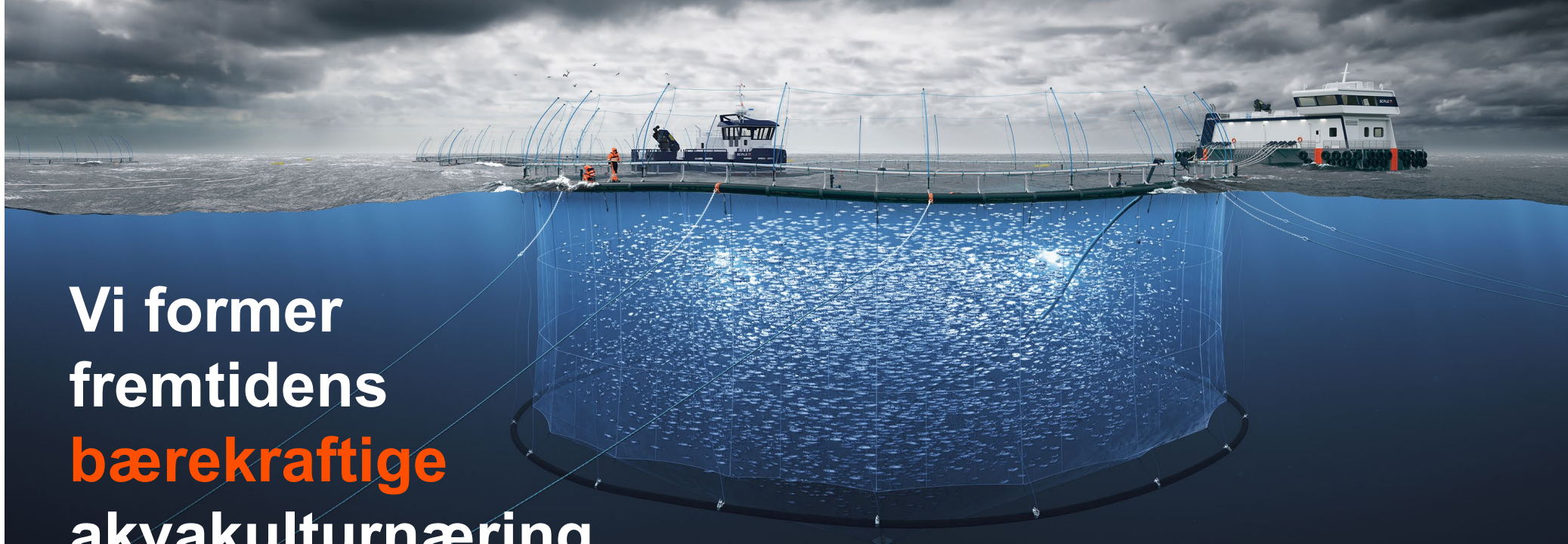

# Vi former fremtidens bærekraftige akvakulturnæring

## EGEN VERDIKJEDE



**Mål:** Vi skal redusere vårt fotavtrykk og sørge for økt sirkularitet i vår egen verdikjede, inkludert underleverandører.

**Tiltak:** Kartlegging av eget klimaavtrykk, returordninger, pilotprodukt laget av resirkulert materiale.

## KUNDENE VÅRE



**Mål:** Med nye og eksisterende produkter og løsninger, samt rådgivning bidra til at kundene blir mer bærekraftige.

**Tiltak:** Dokumentasjon og sporbarhet, bærekraftsrapporter, kundenettverk, utvikle produkter som imøtekommer miljøkrav.



## SUSTAINABLE DEVELOPMENT GOALS

### BRANSJE OG SAMFUNN

**Mål:** Gjennom økt samfunnsengasjement ta en tydelig bransjerolle innen bærekraft.

**Tiltak:** FNs bærekraftsmål, bærekraftsnettverk, rapportering, sertifisering, kommunikasjon.

9 INDUSTRI,  
INNOVASJON OG  
INFRASTRUKTUR



12 ANSVARLIG  
FORBRUK OG  
PRODUKSJON



13 STOPPE  
KLIMAENDRINGENE



14 LIVET I  
HAVET



17 SAMARBEID  
FOR Å NÅ MÅLENE





# Innovasjon & Utvikling

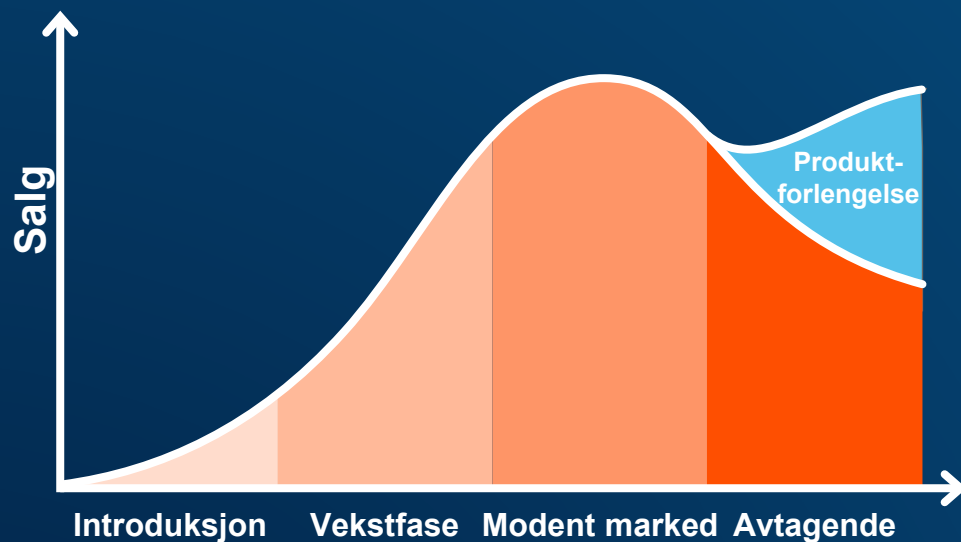

Produkter kommer og går – alt er i kontinuerlig utvikling

- Den som står stille, forsvinner
- Vi må være i kontinuerlig endring
- Alle må/kan bidra
  - I&D skal prøve å **koordinere** jobben - ikke **gjøre** jobben

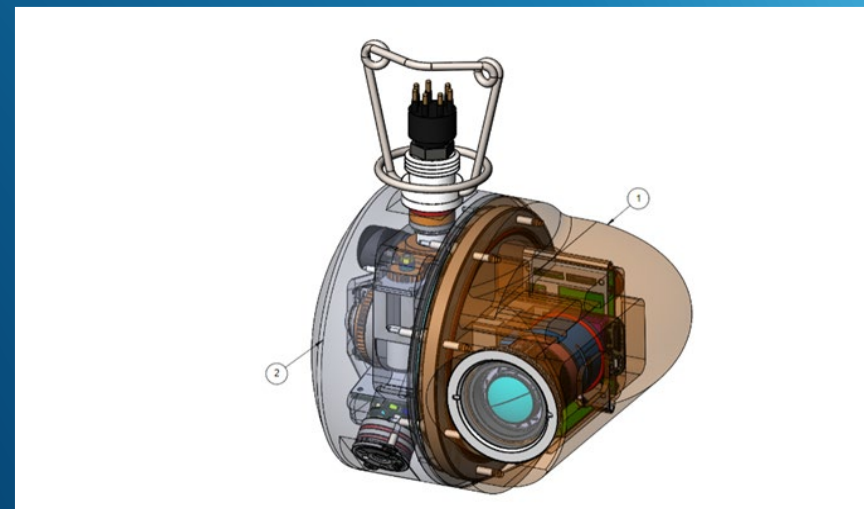

## Produktlanseringer i 2021:

- Vannføring (Q3)
- Pelletdetektor CAS (Q4)
- Motorisert spredder (AquaNor)
- Nytt HD kamera (AquaNor)



*build trust*

*take responsibility*

*go beyond*

**WE ARE**  
**AQUACULTURE**

SCALE **AA**