



SCALE **AD**

# Town hall

February 2021



# Agenda

---

- Recap of 2020
- ScaleAQ building for the future
- A shift in land-based investment
- Financial status
- ScaleUp 250
- Seabased becomes one company
- A front runner in the salmon industry
- Sustainability
- Innovation



# Recap of 2020

---

2020 was a challenging year, a demanding rollercoaster!



# Recap of 2020

---

- Pandemic

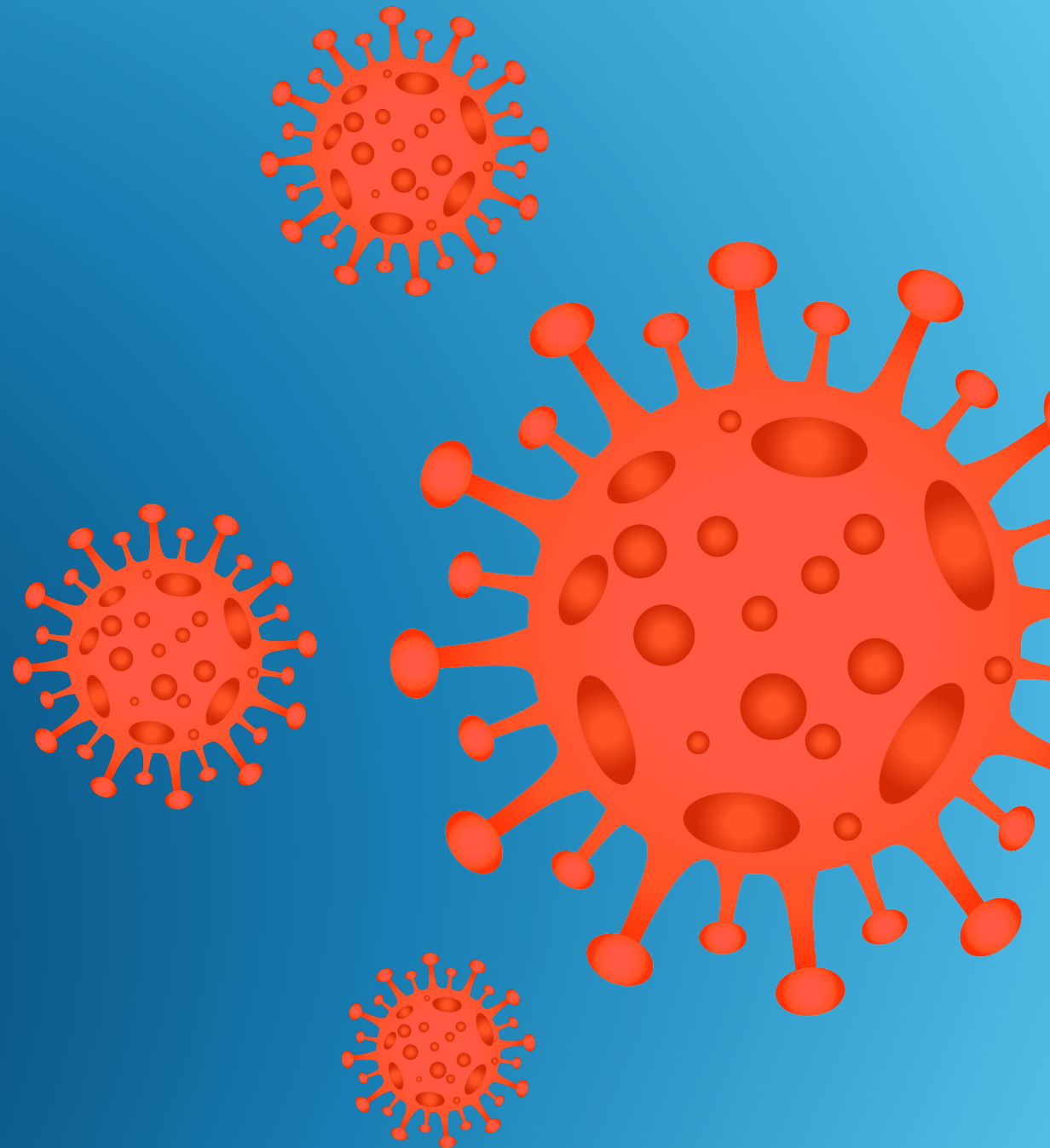



# Recap of 2020

---

- Home office
- Infection prevention rules





HACKED



# Recap of 2020

---

- Hacking





# Recap of 2020

---

- Two companies, on their way to become one
  - Restructuring
  - All time high order book
- 
- And amazing work from the whole team!





# ScaleAQ builds for the future



## ScaleUP 250 – organizational actions

- **3 focused business areas** Sea-based / Land-based / Boat - with dedicated management teams
- Acquisitions of new companies **on-hold** until further notice to ensure focus on integration and improvement measures
- Optimize **Canada, UK and Oceania** from stand-alone companies to a pure role as KAM and service function
- Changes in the **Mediterranean** set-up - sales in these markets will be handled directly from Norway – strong local partnership on service and installation to be established where required
- Initiation of sales process for department **Sykkylven**
  
- A **clear prioritization of development work** for the next 6 - 12 months
- Closing of Project **OKDA**
- Mechatronics is moved to Innovation & Development, **closer collaboration across product groups**
  
- The department in Haugesund takes increased responsibility for stronger control of **global project management**
- Integrated **Supply Chain** (South / Central / North), Bømlo is being built as a base in the south
- Relocation from Frakkagjerd, to more suitable premises in **Haugesund**

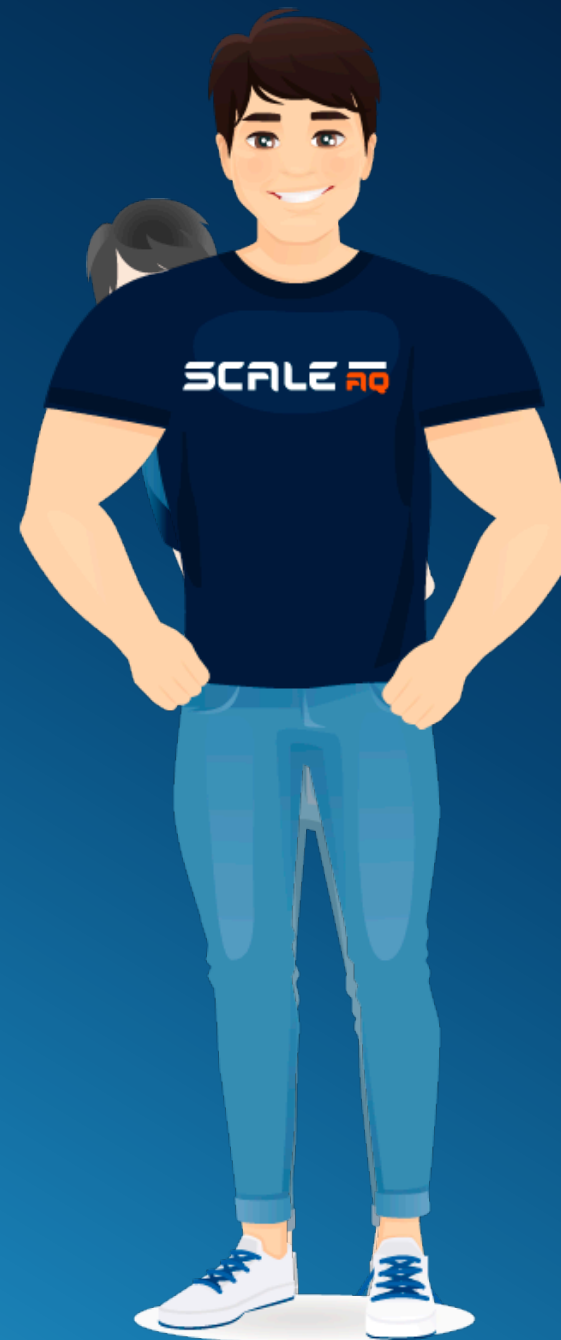



# A shift in landbased investment – from turn-key to CAS

- ScaleAQ shelves future investments in land-based turn key-projects.
- All active projects will be completed as planned.
- ScaleAQ focuses investments towards **CAS (Closed Aquaculture Systems)**
- We will be building on synergies, focusing on our ScaleAQ-strengths.
  - Sea based facilities
  - Feeding, monitoring, and sensorics
  - Consulting
- The company is being reorganized to accommodate these changes.
  - Downsizing - about 6-8 people
  - Keeping a smaller core team



# Financial status

---



# KEY NUMBERS FINANCE (MNOK)

### Turnover \*)

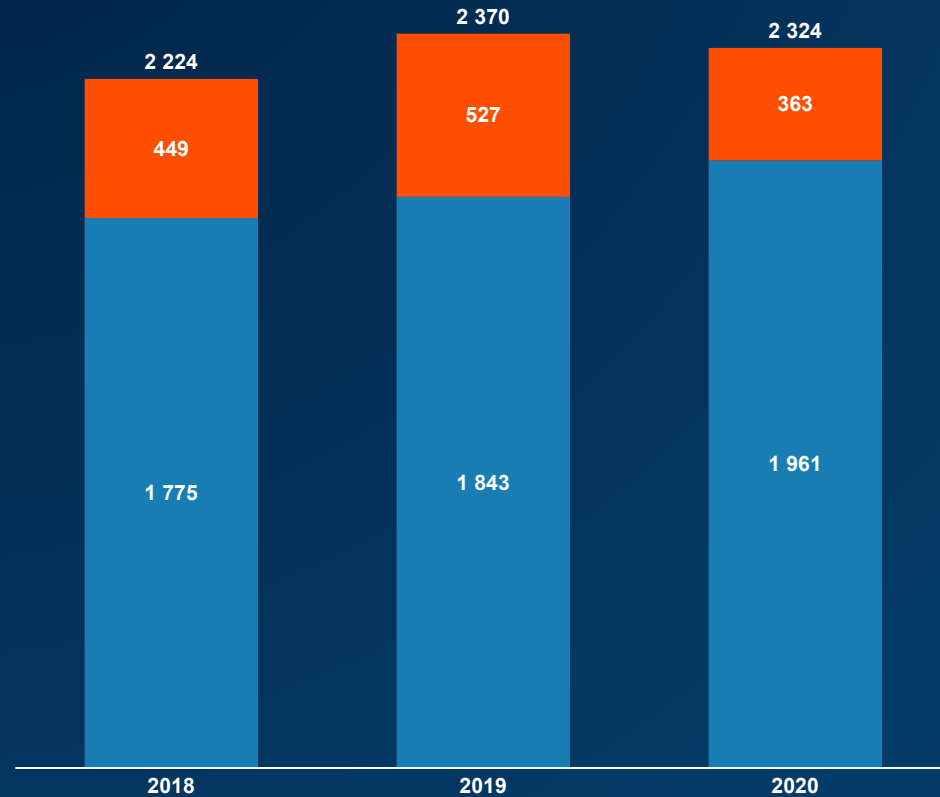

**Moen Marin**  
**Seabased**

### Operating profits before depreciation (EBITDA) \*)

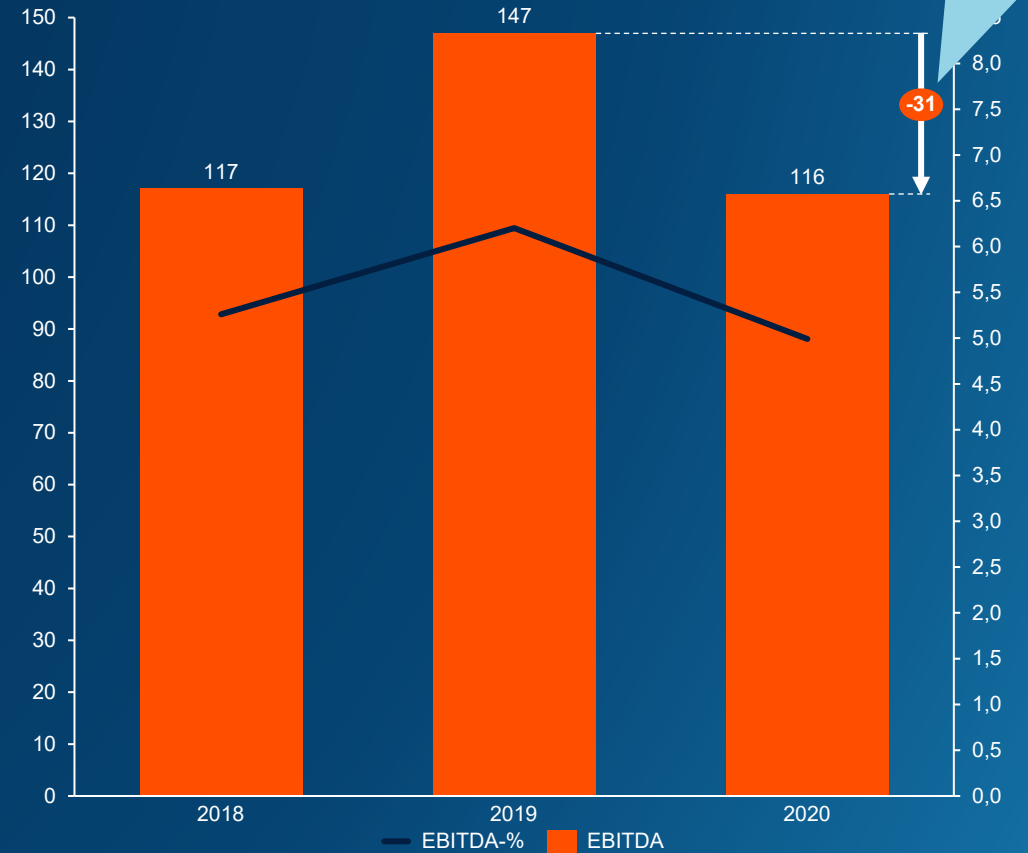

- Boat constitutes losses of 31 MNOK, a consequence of COVID-19.
- Sea-based remains stable!

\*)Scale Aquaculture Group ex AquaOptima – discontinued business



# A SOLID POSITION IN THE GLOBAL SALMON MARKET

## Turnover distributed by region

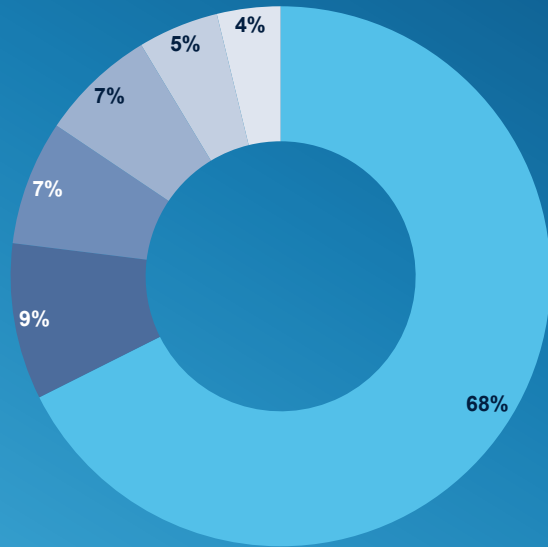

Norway Iceland UK  
Chile Canada Other

2.32 bn. NOK

## Turnover distributed by product

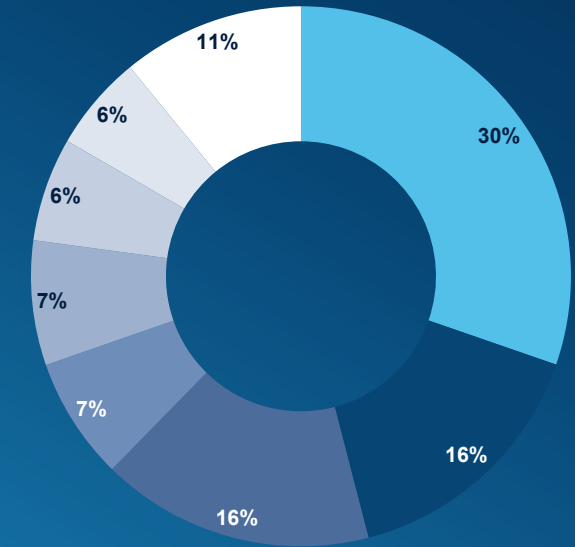

Cages Feeding Nets Camera  
Boats Mooring Service Other



# ALL TIME HIGH ORDER ENTRY

Development unfilled orders jan 2019 – dec 2020

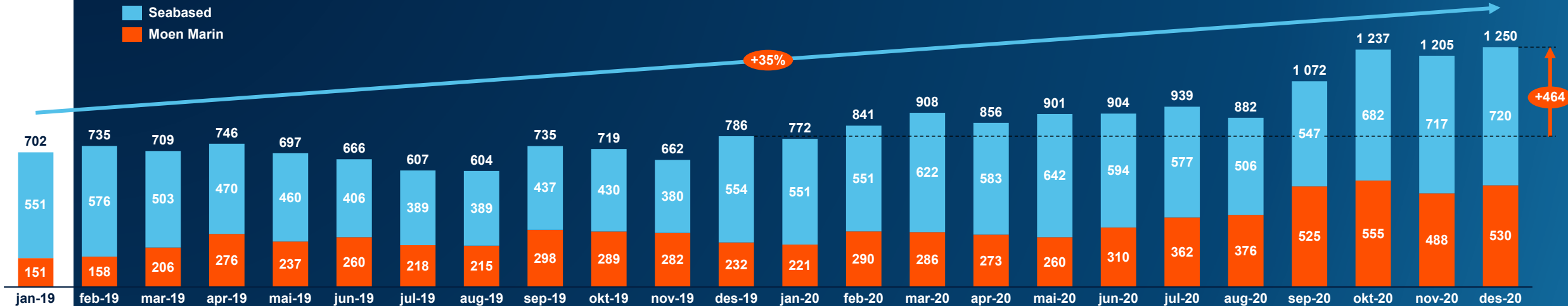



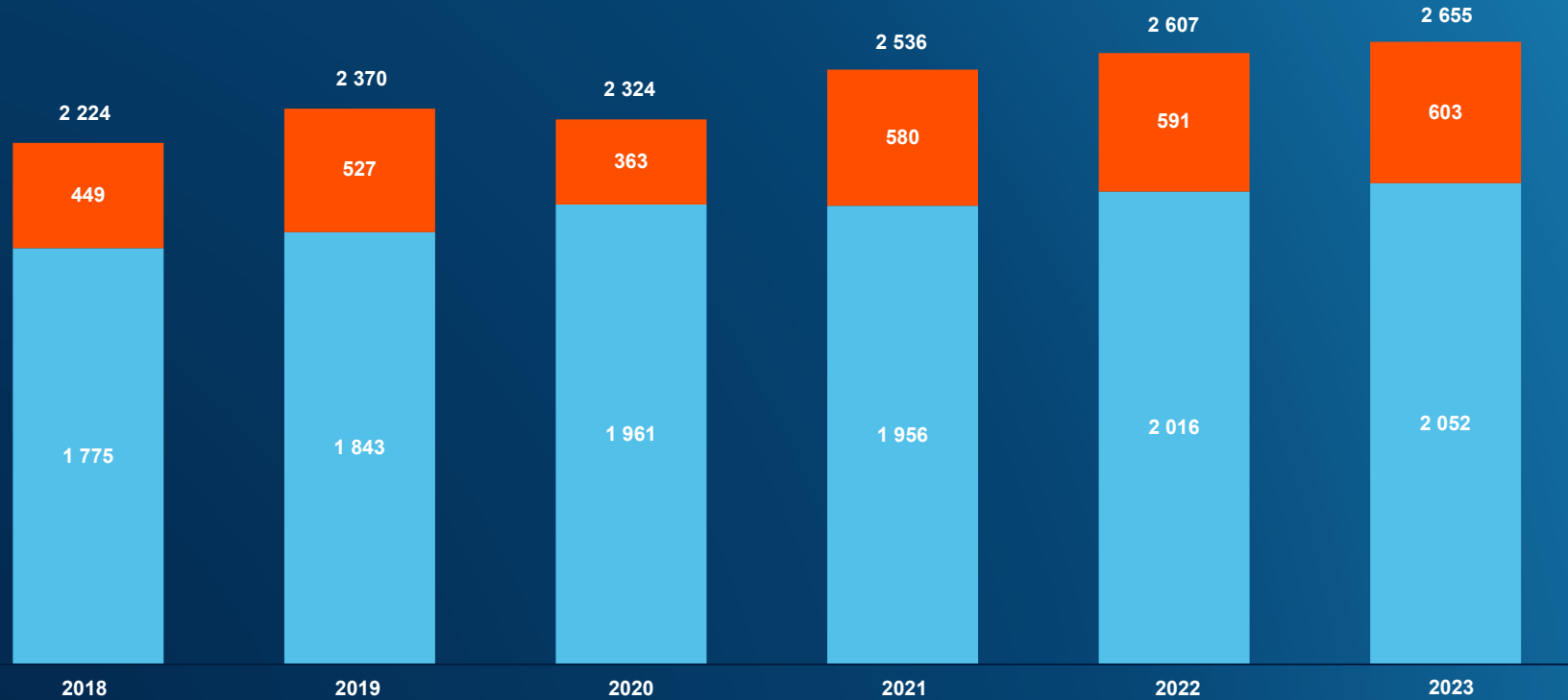

# ScaleUp 250

Turnover



 Moen Marin  
 Seabased



# Our foundation is solid: Together we will improve further

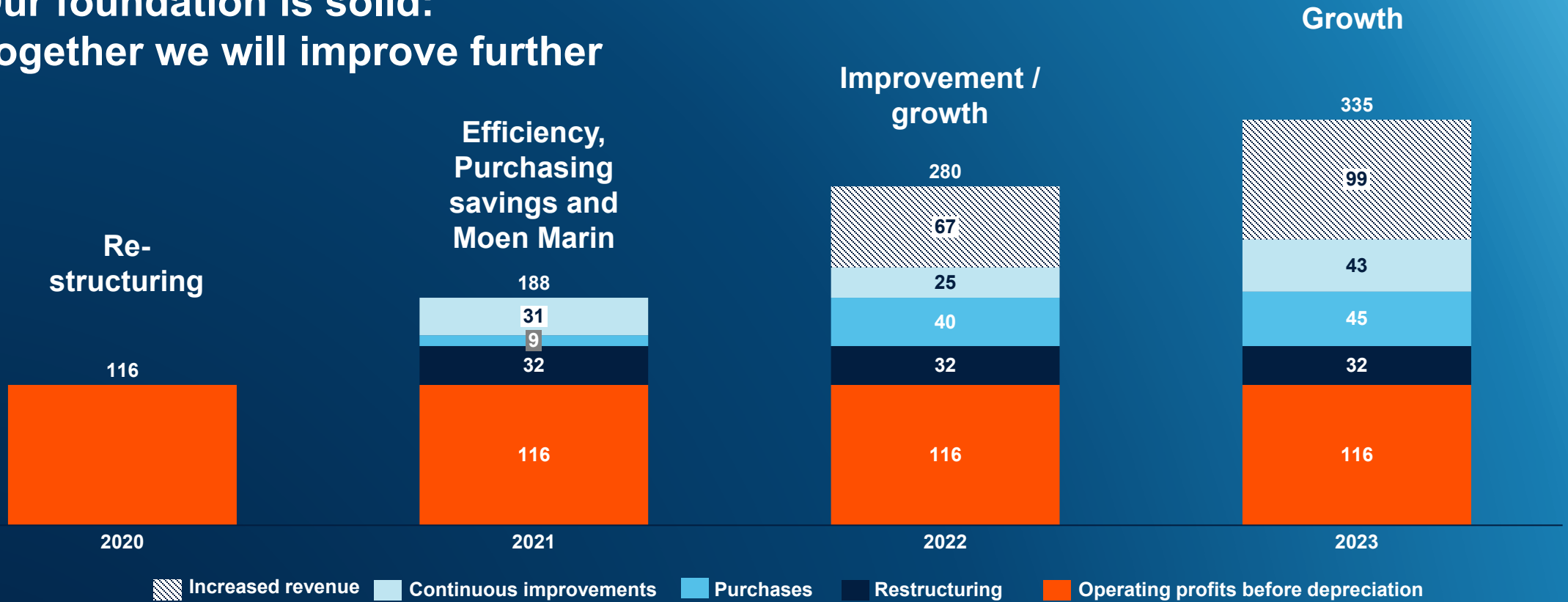

- Focusing on Salmon markets
- Restructuring
- Re-organization

- Organizational coordination
- Purchasing savings
- Improving how we work
- Moen Marin: return to glory

- Purchasing savings
- Improving how we work
- Acquire market shares
- New products
- Utilizing rental as sales options

- Purchasing savings
- Improving how we work
- Acquire market shares
- New products
- Utilizing rental as sales options



# Sea-based becomes one company



- Business as usual
- Legal structure = operational structure
- Scale Rental – a separate company available to the whole group.
- No consequences for the employees, apart from the name change.
- Strengthen branding – avoid confusion with market communication – Scale vs Steinsvik and Aqualine
- Contribute to the creation of one Scale – establishing a value based culture across the whole group – deconstruction of corporate point of view.



# SCALEAQ – A FRONT RUNNER IN THE SALMON INDUSTRY

# SCALE AQ



SUSTAINABILITY – INNOVATION – DIGITALIZATION

A **partner** for the aquaculture industry

*From tailored solutions to complete turnkey projects*

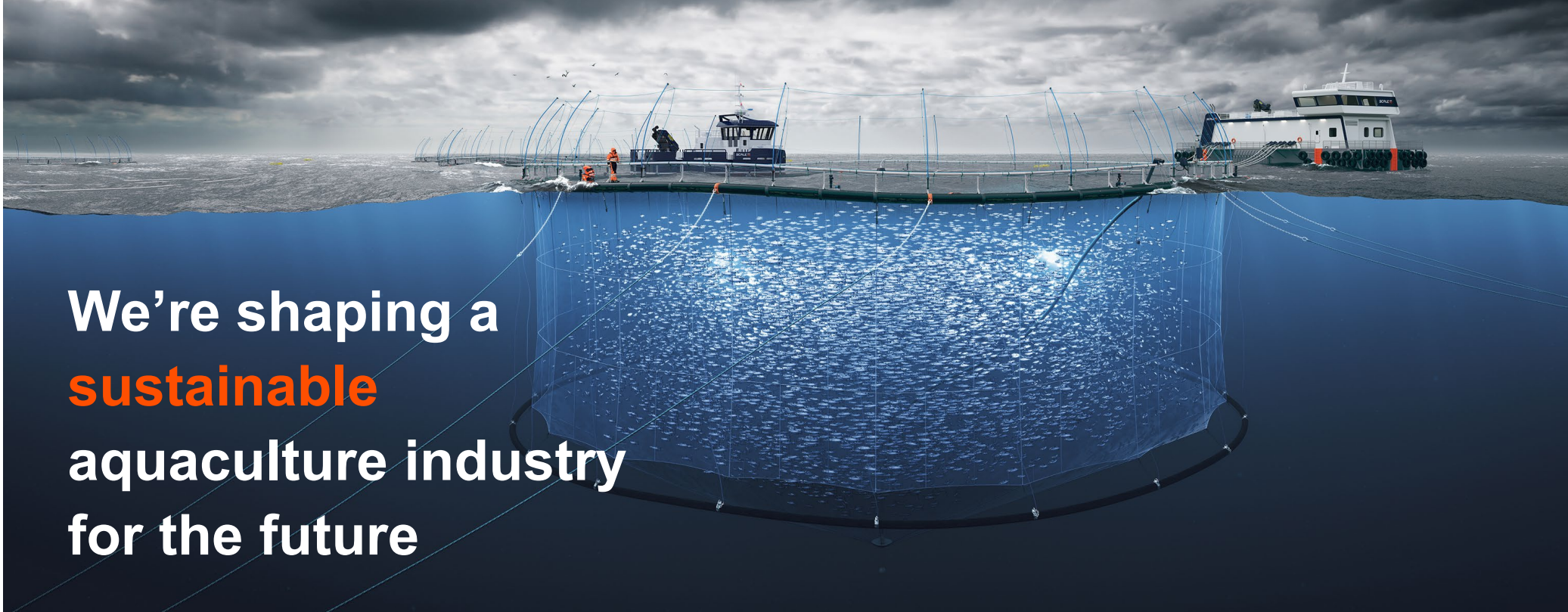

# We're shaping a sustainable aquaculture industry for the future

## OUR OWN VALUE CHAIN



**Goal:** Reducing our own climate footprint and contribute to greater circularity in our own value chain, including subcontractors

**Measures:** Mapping our own climate footprint, product return process, pilot products made from recycled materials.

## OUR CUSTOMERS



**Goal:** Using both new and existing products and solutions, including consulting services, contributing to our customers becoming more sustainable

**Measures:** Documentation and traceability, sustainability reports, customer networks, develop products in line with environmental requirements.



## SUSTAINABLE DEVELOPMENT GOALS

### INDUSTRY AND SOCIETY

**Goal:** By increasing community involvement, take a clear industry role with regards to sustainability

**Measures:** UN's sustainable development goals, sustainability networks, reporting, certifications, communication.

9 INDUSTRY, INNOVATION AND INFRASTRUCTURE



12 RESPONSIBLE CONSUMPTION AND PRODUCTION



13 CLIMATE ACTION



14 LIFE BELOW WATER

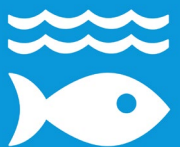

17 PARTNERSHIPS FOR THE GOALS





# Innovation & Development

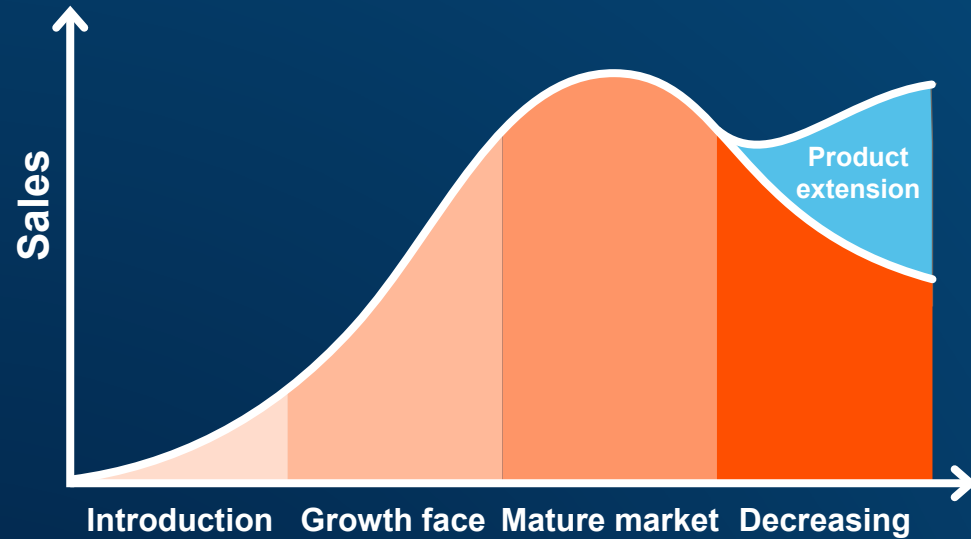

Products come and go – everything is constantly evolving

- The one who does not move, recedes from view
- We must constantly remain in motion
- Everyone must/ can contribute
  - I&D should attempt to **coordinate** the job - not **perform** it

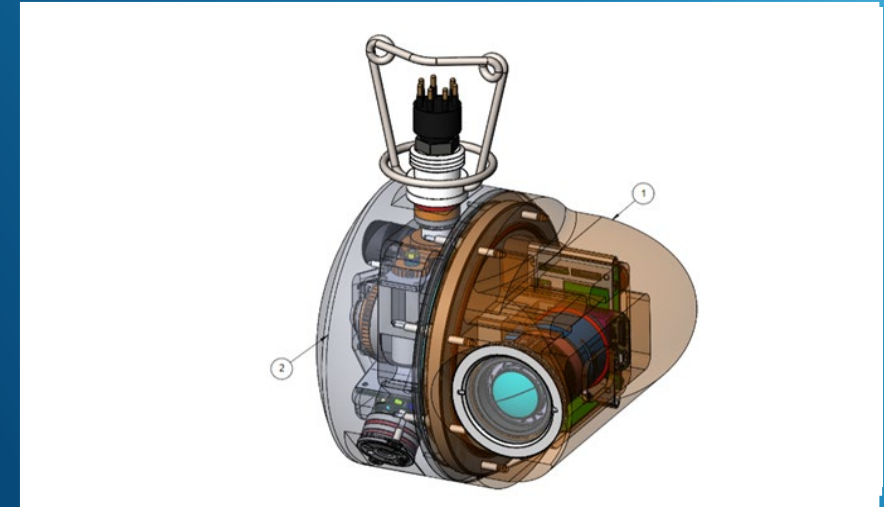

## Products launching in 2021:

- Water feeding (Q3)
- Pellet detector CAS (Q4)
- New Rotofeeder (AquaNor)
- New HD Camera (AquaNor)



*build trust*

*take responsibility*

*go beyond*

**WE ARE**  
**AQUACULTURE**

SCALE **AA**